

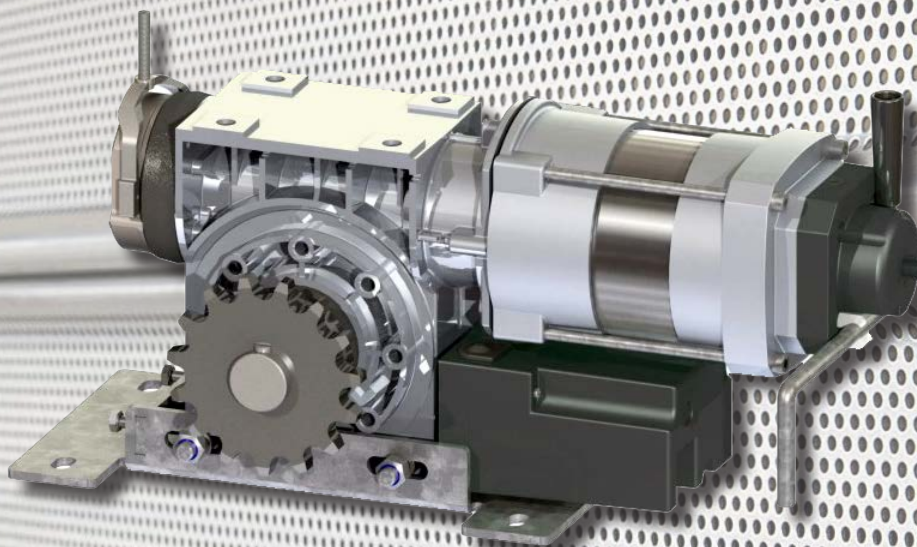



Chain Wheel Operators



CD series

-  FITTED FOR ALL TYPES OF ROLLING DOORS AND GRILLES
-  SUITABLE FOR EXTREME HEAVY AND WIDE DOORS
-  IDEAL FOR DOORS WITH LIMITED SIDE ROOM



Chain Wheel Operators

- CD operators are designed to operate heavy and wide non counterbalanced rolling doors and grilles
- CD is connected with the door shaft via a chain system
- Suitable for special installation situations or high door weights
- Mounted quickly and securely using the supplied fixing brackets
- Equipped with a mounting bracket, which enables easy and correct chain tension adjustment on the tightening screw
- Output torque from 130 Nm to 1650 Nm
- Output speed from 22 -25 rpm with four gearbox sizes (2,3,4, 6) in 400 V, 3-phase, 230 V, 3-phase
- Mechanical accessories such as Roller chains, sprockets, shafts, and Roll-Off Safety Device are available



Special configurations

On demand it is possible to adjust our operators to meet higher requirements (i.e. UL/CSA- or IEC-Certification, higher duty ratio) with the mounting of special motors. We also offer increased protection for the operators for harsh and corrosive environment (i.e. outdoor, coastal, cold storage).



Limit switch

The door position is monitored by a directly integrated camshaft with an internal limit ratio of 10:1, 15:1, 20:1 or 40:1. All operators can be supplied with two different limit switch systems:

- Cam Switch
- Digital Encoder (single-turn, multi-turn)



Emergency Operation

In order to operate the door in case of a power failure, all operators come with a emergency hand system.

If the operator is equipped with a DC-brake, ensure that the release lever is not pushed manually during the crank operation.

Choose between the following manual overrides:

- Haul Chain Mechanism (KE)
- Haul Chain Mechanism (KM) for Heavy duty doors
- Short Hand Crank (KU)



Plug-in connections

All connections are pluggable and reverse polarity protected. Using push-in fittings, we guarantee a quick and easy mounting.



Brake

All Tornado gearboxes can be equipped with a spring-applied brake (holding brake) or an electromagnetic brake (working current brake). The brake can be fitted on the gearbox or motor side, depending on requirements.

- | | |
|--------------------------------------|-----------------------------------|
| • Spring-applied brake: | • Electromagnetic brake: |
| - Braking torque from 2Nm to 40Nm | - Braking torque 7.5Nm or 15Nm |
| - Brake voltage 24V/DC or 205V/DC | - Brake voltage 24V/DC or 205V/DC |
| - Designed for 100% duty cycle | - Designed for 100% duty cycle |
| - Protection class IP54 or IP65 | - Protection class IP44 |
| - With or without manual release | - Brake rectifier (on request). |
| - Brake rectifier (on request) | |
| - Preset air gap (on request) | |
| - UL/CSA version (on request) | |
| - Noise-damped versions (on request) | |



External Roll-Off Safety Device

For loads that need to be secured against falling, an external safety catch device is required.

Gearbox size 2

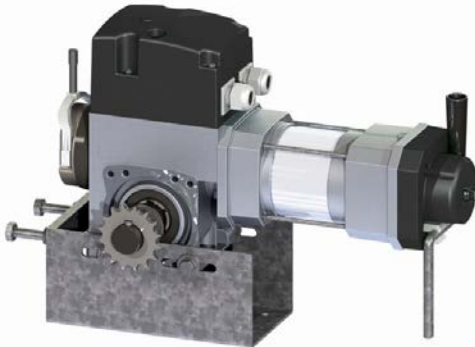

Gearbox size 4



Short Hand Crank (KU)



Haul Chain Mechanism (KE)

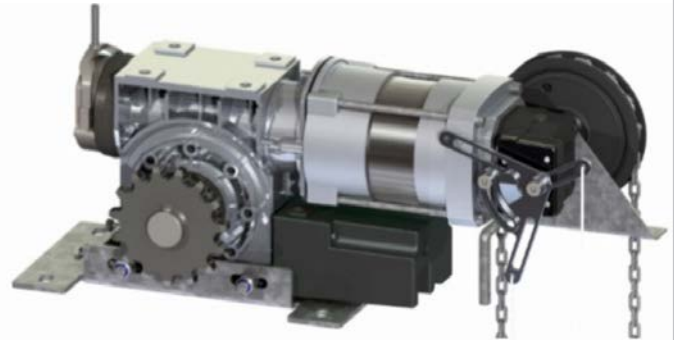

Digital Encoder

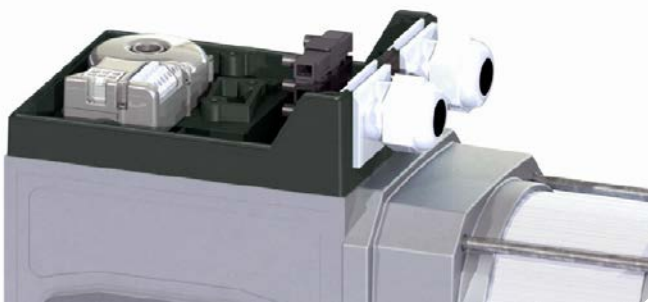

Cam Switch

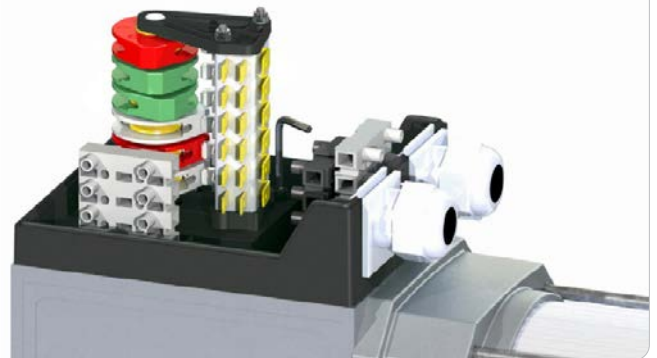

Duty Ratio MD



Duty Ratio HD



Table Curtain Speed (v) and Lifting Force

The following chain ratios are available: 1:1, 1:2, 1:3 and 1:3.8.

The values in the table take into account 20% safety reserve. With stacking doors or unfavorable winding conditions (e.g. door height greater than width of the door, unfavorable inlet, extra gaskets, double-profiles) are indicated to reduce the lifting forces by about another 20%.

Selecting the right operator

To select the right operator following parameters are necessary: The diameter of the winding shaft, the weight and the thickness of the door leaf. The median coil-diameter is required for rolling doors because the coil-diameter increases due to the rolling-up of the gate and hence the speed is not constant. The values from the table are therefore only for guidance.

Using this data the appropriate operator could be determined from the following tables:

Chain Ratio: 1:1	Tube-Diameter / Median Coil-Diameter ¹⁾ [mm]									
	100	130	160	190	220	250	270	300	350	400
v @ n2=25 min ⁻¹ [cm/s]	13	17	21	25	29	33	35	39	46	52
v @ n2=24 min ⁻¹ [cm/s]	13	16	20	24	28	31	34	38	44	50
v @ n2=23 min ⁻¹ [cm/s]	12	16	19	23	26	30	33	36	42	48
v @ n2=22 min ⁻¹ [cm/s]	12	15	18	22	25	29	31	35	40	46
CD-130 [N]	2080	1600	1300	1094	945	832	770	693	594	520
CD-300 [N]	4800	3962	3000	2526	2181	1920	1777	1600	1371	1200
CD-350 [N]	5600	4307	3500	2947	2545	2240	2074	1866	1600	1400
CD-550 [N]	8800	6769	5500	4631	4000	3520	3259	2933	2514	2200
CD-750 [N]	12000	92300	7500	6315	5454	4800	4444	4000	3428	3000
CD-1000 [N]	16000	12307	10000	8421	7272	6400	5925	5333	4571	4000
CD-1250 [N]	20000	15384	12500	10526	9090	8000	7407	6666	5714	5000
CD-1650 [N]	26400	20307	16500	13894	12000	10560	9777	8800	7542	6600

1) The median coil-diameter results from the initial roll diameter + slat thickness and the diameter of the fully rolled-up door (to be taken from the coil-diameter table of the profile supplier), e.g. roll diameter Ø 160 mm, slat thickness 20 mm, coil-diameter upper end position Ø 400 mm -> median coil-diameter (160 + 20 + 400) : 2 = 290 mm

Chain Ratio: 1:2	Tube-Diameter / Median Coil-Diameter ¹⁾ [mm]									
	100	130	160	190	220	250	270	300	350	400
v @ n2=25 min ⁻¹ [cm/s]	6	8	10	12	14	16	17	19	22	26
v @ n2=24 min ⁻¹ [cm/s]	6	8	10	11	13	15	16	18	21	25
v @ n2=23 min ⁻¹ [cm/s]	6	7	9	11	13	15	16	18	21	24
v @ n2=22 min ⁻¹ [cm/s]	5	7	9	10	12	14	15	17	20	23
CD-130 [N]	4160	3200	2600	2188	1890	1664	1540	1386	1188	1040
CD-300 [N]	9600	7384	6000	5052	4362	3840	3554	3200	2742	2400
CD-350 [N]	11200	8614	7000	5894	5090	4480	4148	3732	3200	2800
CD-550 [N]	17600	13538	11000	9262	8000	7040	6518	5866	5028	4400
CD-750 [N]	24000	18460	15000	12630	10908	9600	8888	8000	6856	6000
CD-1000 [N]	32000	24614	20000	16842	14544	12800	11850	10666	9142	8000
CD-1250 [N]	40000	30768	25000	21052	18180	16000	14814	13332	11428	10000
CD-1650 [N]	52800	40614	33000	27788	24000	21120	19554	17600	15084	13200

Chain Ratio: 1:3	Tube-Diameter / Median Coil-Diameter ¹⁾ [mm]									
	100	130	160	190	220	250	270	300	350	400
v @ n2=25 min ⁻¹ [cm/s]	4	5	6	8	9	10	11	13	15	17
v @ n2=24 min ⁻¹ [cm/s]	4	5	6	7	9	10	11	12	14	16
v @ n2=23 min ⁻¹ [cm/s]	4	5	6	7	8	10	10	12	14	16
v @ n2=22 min ⁻¹ [cm/s]	3	4	6	7	8	9	10	11	13	15
CD-130 [N]	6240	4800	3900	3282	2835	2496	2310	2079	1782	1560
CD-300 [N]	14400	11076	9000	7578	6543	5760	5331	4800	4113	3600
CD-350 [N]	16800	12921	10500	8841	7635	6720	6222	5598	4800	4200
CD-550 [N]	26400	20307	16500	13893	12000	10560	9777	8799	7542	6600
CD-750 [N]	36000	27690	22500	18945	16362	14400	13332	12000	10284	9000
CD-1000 [N]	48000	36921	30000	25263	21816	19200	17775	15999	13713	12000
CD-1250 [N]	60000	46152	37500	31578	27270	24000	22221	19998	17142	1500
CD-1650 [N]	79200	60921	49500	41682	36000	31680	29331	26400	22626	19800

Chain Ratio: 1:3,8	Tube-Diameter / Median Coil-Diameter ¹⁾ [mm]									
	100	130	160	190	220	250	270	300	350	400
v @ n2=25 min ⁻¹ [cm/s]	3	4	5	6	7	8	9	10	12	13
v @ n2=24 min ⁻¹ [cm/s]	3	4	5	6	7	8	8	9	11	13
v @ n2=23 min ⁻¹ [cm/s]	3	4	5	6	6	7	8	9	11	12
v @ n2=22 min ⁻¹ [cm/s]	3	3	4	5	6	7	8	9	10	12
CD-130 [N]	7904	6080	4940	4157	3591	3162	2926	2633	2257	1976
CD-300 [N]	18240	14030	11400	9599	8288	7296	6753	6080	5210	4560
CD-350 [N]	21280	16367	13300	11199	9671	8512	7881	7091	6080	5320
CD-550 [N]	33440	25722	20900	17598	15200	13376	12384	11145	9553	8360
CD-750 [N]	45600	35074	28500	23997	20725	18240	16887	15200	13026	11400
CD-1000 [N]	60800	46767	38000	32000	27634	24320	22515	20265	17370	15200
CD-1250 [N]	76000	58459	47500	39999	34542	30400	28147	25331	21713	19000
CD-1650 [N]	100320	77167	62700	52797	45600	40128	37153	33440	28660	25080

Technical data

	Gearbox Size	Starting Torque	Nominal Torque	Output Speed	Limit capacity ²⁾	Hollowshaft Diameter ³⁾	Operating Voltage (50 Hz)	Motor Output	Motor Duty Cycle ⁴⁾	Nominal Current 230 / 400 V	See Drawing / Length L ₁	Type of manual operation	Protection Category	Weight
Operator Type		M _A [Nm]	M _N [Nm]	n ₂ [min ⁻¹]	i _{stW}	D [mm]	U [V]	P [kW]		I _N [A]	L ₁ [mm]		IP	m [kg]
CD-130.24 ¹⁾	2	130	110	24	20	30	3~230 3~400	0,55	MD	3,54 2,0	264	KU KE	54	17
CD-300.23 ¹⁾	3	300	250	24	20	40	3~230 3~400	1,5	MD	6,9 4,0	320	KU KE	54	32
CD-350.23 ¹⁾	4	350	310	23	40	40	3~230 3~400	1,5	MD	6,6 3,8	391	KU KE	54	39
CD-550.23 ¹⁾	4	550	500	23	40	40	3~230 3~400	2,2	MD	9,2 5,3	396	KU KE	54	42
CD-750.22 ¹⁾	6	750	620	22	40	55	3~230 3~400	2,2	MD	9,2 5,3	437	KU KM	54	63
CD-1000.25 ¹⁾	6	1000	850	25	40	55	3~230 3~400	3,0	MD	11,3 6,5	437	KU KM	54	65
CD-1250.25 ¹⁾	6	1250	1100	25	40	55	3~230 3~400	4,0	MD	15,4 8,9	477	KU KM	54	70
CD-1650.25 ¹⁾	6	1650	1400	25	40	55	3~230 3~400	5,5	MD	19,5 11,3	460	KU	54	75

1) Operator is equipped with DC-brake, neutral connection is required.

2) Limit ratio can be changed on request

3) Hollow shaft diameter can be changed on request

4) Duty Ratio HD available on request.

*) Temperature range: -5°C ... 40°C

Dimensions

The following illustrations show all relevant dimensions of our operator series. Refer to the table of technical data for the assignment of the sketches and for dimension L1.

Dimensions of Manual Override

Gearbox Size	Crank Length	Crank-Radius	Length Chain drive	Width Chain-Side	Width Clutch-Side
	L _k [mm]	R _k [mm]	L _c [mm]	B ₁ [mm]	B ₂ [mm]
2	230	80	137	114	95
3	230	185	137	114	95
4	230	185	137	114	95
6	340	220	122	138	108

Gearbox Size 2

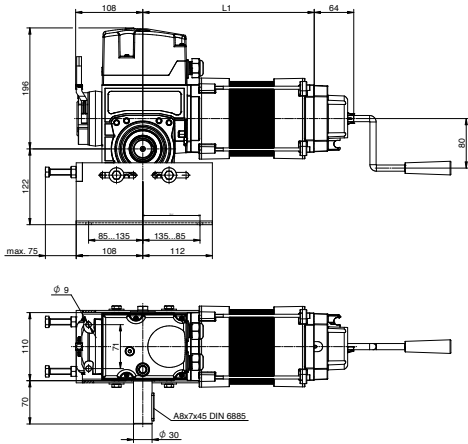

Gearbox Size 3 Bottom encoder case

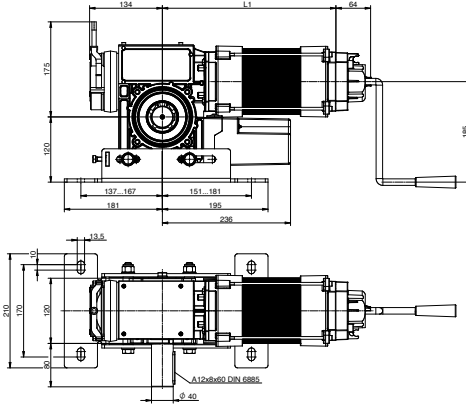

Gearbox Size 3 Top encoder case

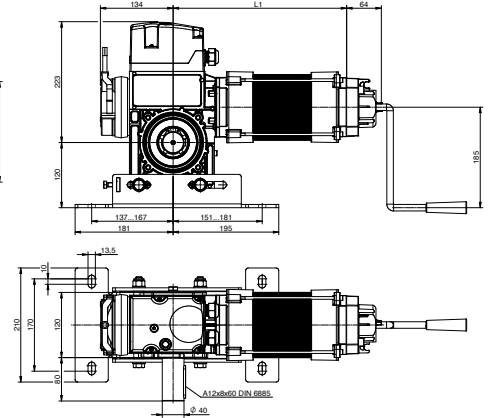

Gearbox Size 4

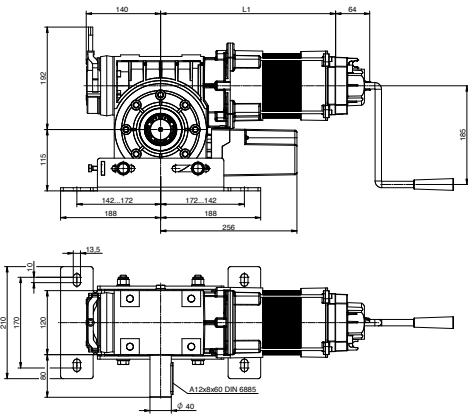

Gearbox Size 6

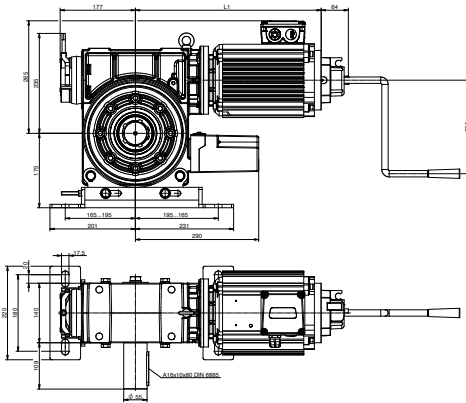

Manual Override

Manual operation KE

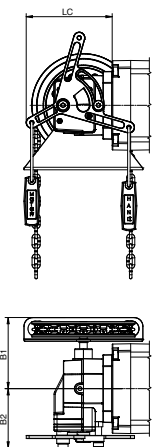

Manual operation KM

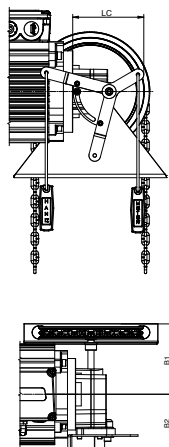

Manual operation KU Size 4

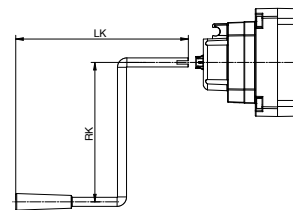

Size 6

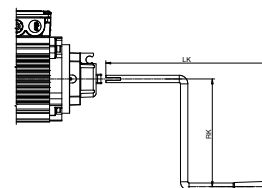

Accessories

Complete your chain wheel operator with our wide range of accessories and control panels to a customized automation package. Find more information in our special catalogs.

Mechanical Accessories



Electronic Accessories



Control Panels (Relay)



Control Panels (VFD)



Tornado Antriebstechnik GmbH | Subject to Modifications
www.tornado-drives.com



- Rolling Door Operators
- Sectional Door Operators
- High-Speed Door Operators
- Chain Wheel Operators
- Sliding Gate Operators
- Control Panels
- Safety Systems
- Accessories